



R6500/1E Microprocessor Emulator Device

INTRODUCTION

The R6500/1E device provides all the features of the R6500/1 Microcomputer in a ROMless form suitable for use as an advanced microprocessor complete with 16-bit counter and 32 I/O lines, and an address and data bus for 4K of external memory.

To aid in designing R6500/1 microcomputer systems, it may also be used as an emulator device. Device architecture is basically the same as the R6500/1 except that the address, data, and associated control lines are routed off the chip for connection to an external memory.

The functions and operation of the R6500/1E device are identical to the R6500/1 except for minor differences noted in this

document. The R6500/1 Product Description (Order No. 212) contains a description of R6500/1 functions and interface signals.

The R6500/1E device is available in both 64-pin ceramic DIP (R6500/1EC) and 64-pin plastic QUIP (R6500/1EQ).

ORDERING INFORMATION

Part Number	Package Type	Frequency Option	Temperature Range
R6500/1EC	Ceramic	1 MHz	0°C to 70°C
R6500/1EAC	Ceramic	2 MHz	0°C to 70°C
R6500/1EQ	Plastic	1 MHz	0°C to 70°C
R6500/1EAQ	Plastic	2 MHz	0°C to 70°C

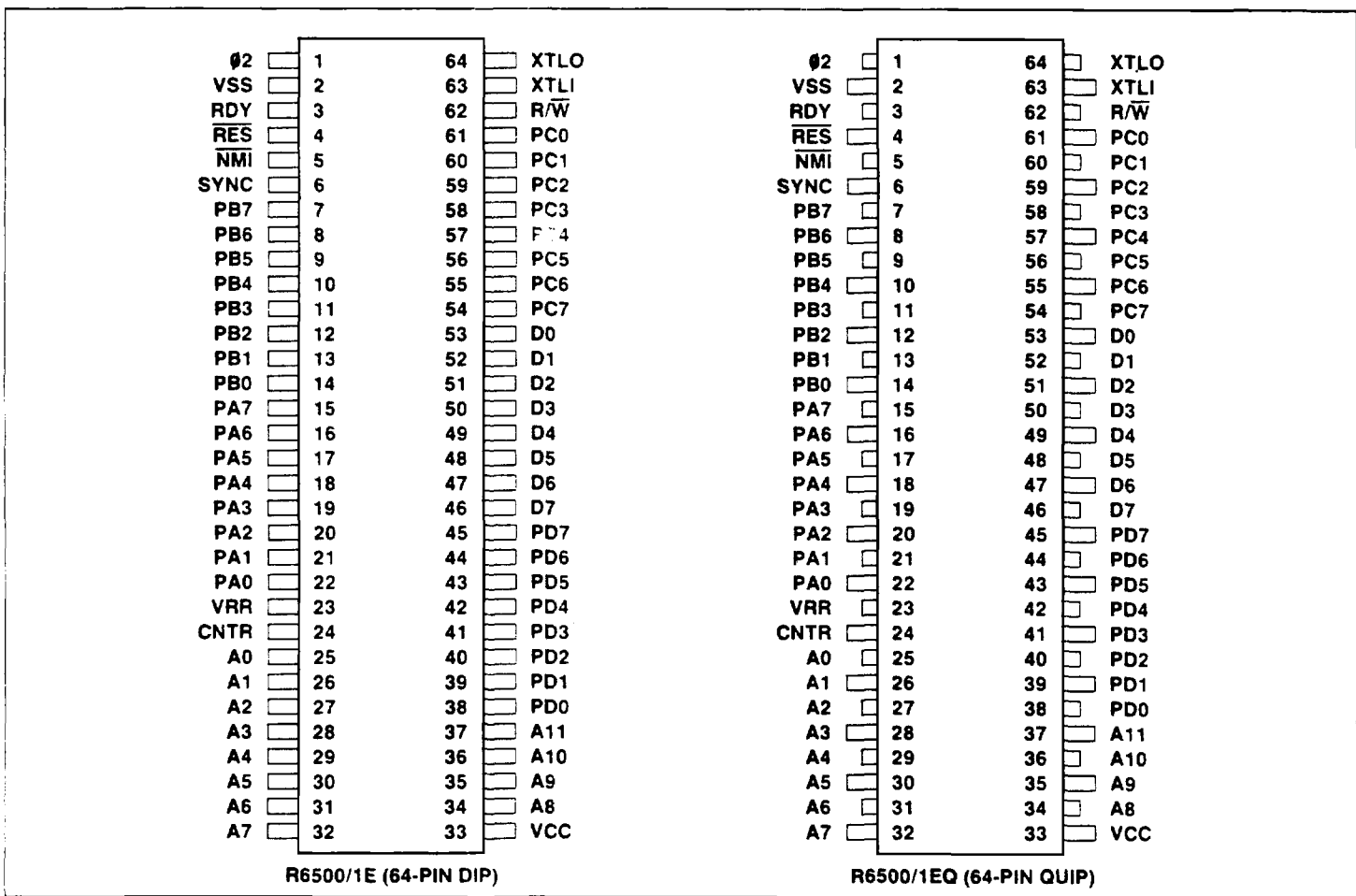

R0CKS007

R6500/1E Pin Assignments

INTERFACE SIGNALS

All R6500/1 interface signals are available in the R6500/1E microcomputer plus the additional address (12), data (8), and control (4) lines required to extend the address bus and the data bus external to the device. The R6500/1E emulator unique interface signals are shown in Figure 1 and are described in Table 1. While the pin assignments are different in order to accommodate 64-pin DIP and QUIP packages, the interface characteristics of signals common to the R6500/1 are identical.

SYSTEM ARCHITECTURE

The architecture of the R6500/1E is identical to the R6500/1 with the following differences:

EXTERNAL ADDRESSING

ROM addressing is routed externally in the R6500/1E. The address range for internal ROM in the R6500/1 (\$800-\$FF9) is available externally for connection to ROM or RAM devices(s).

An additional 1024 bytes (\$400-\$7FF) are decoded for external memory access. Note that this address range can be used for

debugging with the R6500/1E but cannot be used when the object code is transferred to masked ROM in an R6500/1 (which is restricted to \$800-\$FF9).

A memory map of the R6500/1E is shown in Figure 2.

INTERNAL I/O PORT PULL-UPS

The R6500/1E has the internal I/O and CNTR port pull-up resistors only. The option to delete the pull-up resistors is not available for the R6500/1E.

EARLIER I/O PORT INITIALIZATION

Ports A, B, C, D and the CNTR line in the R6500/1E are initialized to the logic high state two $\phi 2$ clock cycles earlier than in the R6500/1. It is still required, however, that the \overline{RES} line be held low for at least eight $\phi 2$ clock cycles after VCC reaches operating range (Figure 3).

WRITE-ONLY MONITORING

The R6500/1E allows the user to monitor write operations to the internal RAM and I/O by routing those operations externally as well as internally. Read operations are not routed externally.

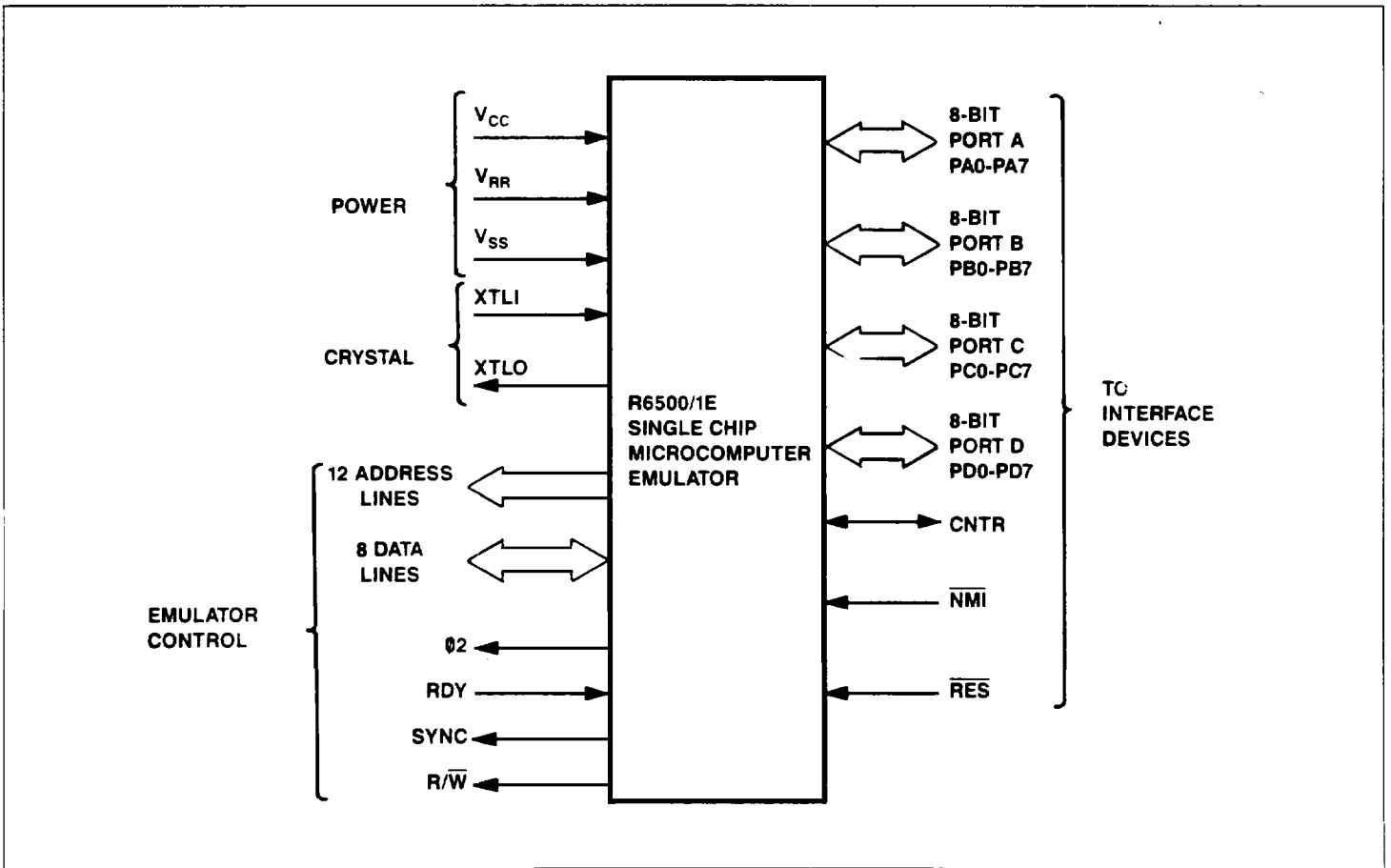

Figure 1. R6500/1E Emulator Interface Diagram

Table 1. R6500/1E Emulator Unique Signals Description

Signal Name	Pin No.	Description
R/W	62	Read/Write. Read/Write allows the CPU to control the direction of data transfer between the R6500/1E Emulator CPU and external memory. This line is high when reading data from memory and is low when writing data to memory.
RDY	3	Ready. The Ready input delays execution of any cycle during which the RDY line is low. This allows the user to halt or single step the CPU on all cycles except write cycles. A negative transition to the low state during the $\phi 2$ clock low pulse will halt the CPU with the address lines containing the current address being fetched. If RDY is low during a write cycle, it is ignored until the following read operation. This condition will remain through a subsequent $\phi 2$ clock pulse in which the RDY line is low. This feature allows the CPU to interface with memories having slow access times, such as EPROMS used with the R6500/1E during prototype system development.
SYNC	6	Sync. The Sync signal is provided to identify cycles in which the CPU is performing OP CODE fetch. SYNC goes high during the $\phi 2$ clock low pulse of an OP CODE fetch and stays high for the remainder of that cycle. If the RDY line is pulled low during the $\phi 2$ clock low pulse in which SYNC went high, the CPU will halt in its current state and will remain in that state until the RDY line goes high. Using this technique, the SYNC signal can be used to control RDY to cause single instruction execution.
$\phi 2$	1	Phase 2 ($\phi 2$) clock: Data transfer takes place only during $\phi 2$ clock pulse high.
A0-A11	25-37	Address Bus Lines. The address bus buffers on the R6500/1E are push/pull type drivers capable of driving at least 130 pF and one standard TTL load. The address bus always contains known data. The addressing technique involves putting an address on the address bus which is known to be either in program sequence, on the same page in program memory, or at a known point in memory. The I/O address commands are also placed on these lines.
D0-D7	53-46	Data Bus Lines. All transfers of instructions and data between the CPU and memory, I/O, and other interfacing circuitry take place on the bidirectional data bus lines. The buffers driving the data bus lines have full three-state capability. Each data bus pin is connected to an input and output buffer, with the output buffer remaining in the floating condition.

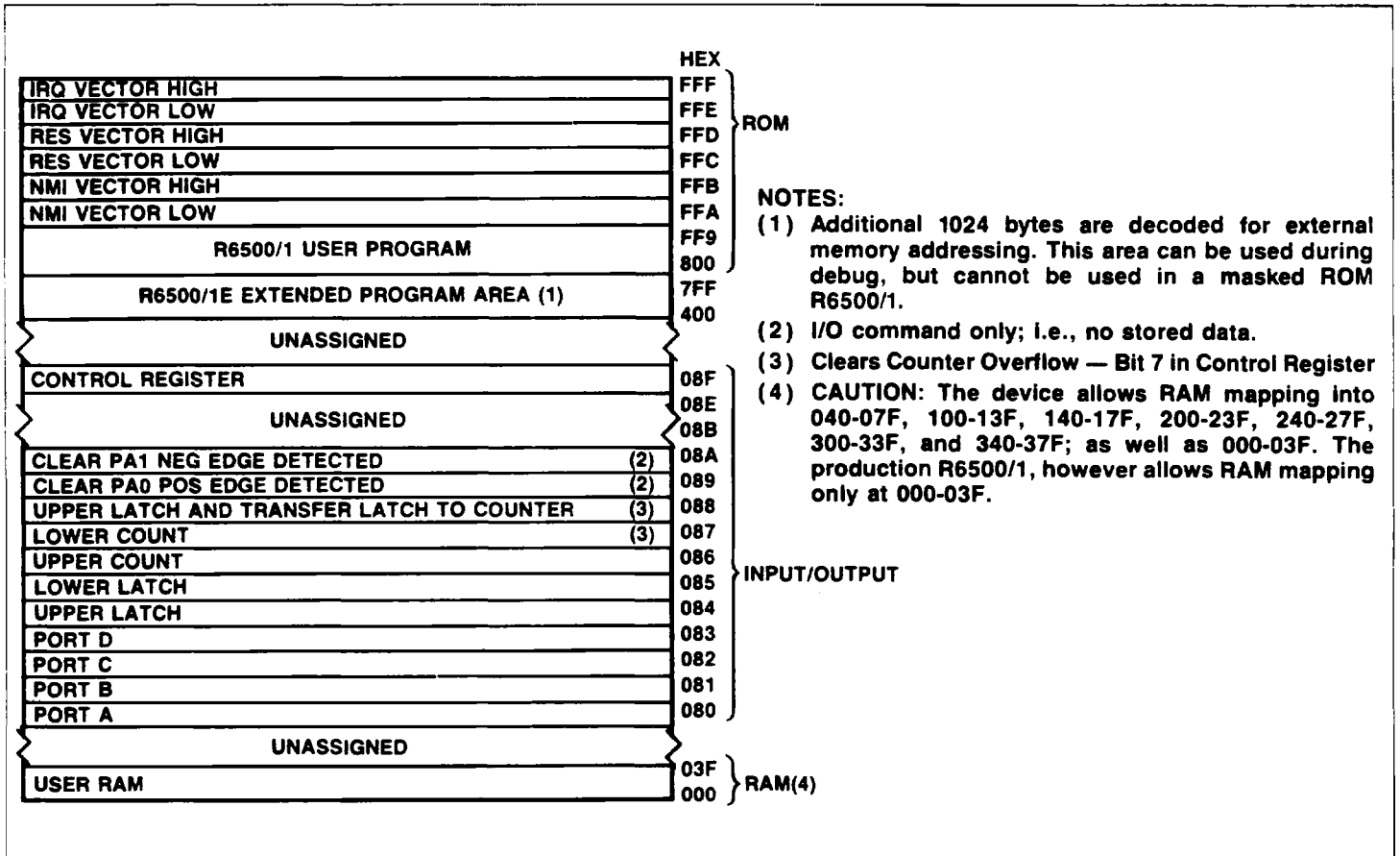

Figure 2. R6500/1E Memory Map

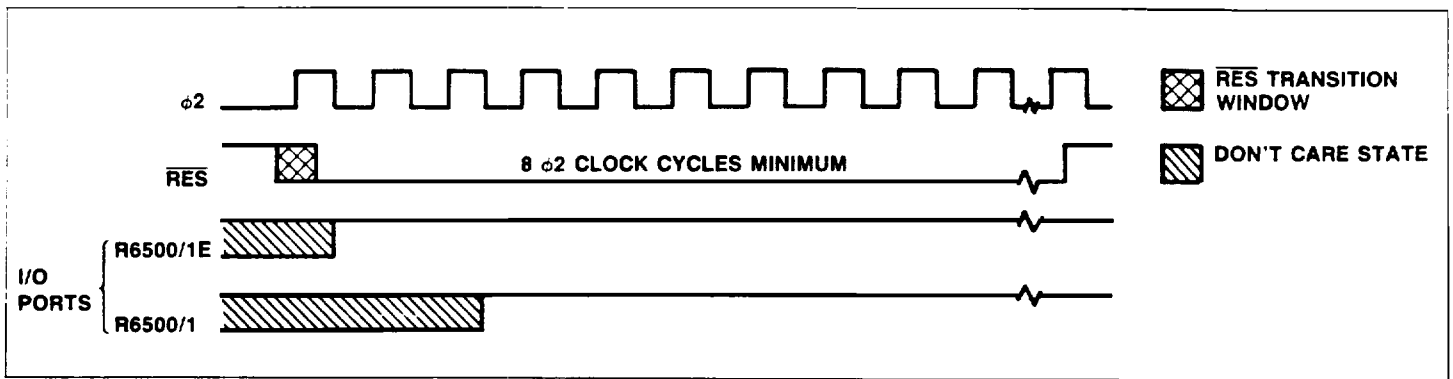

Figure 3. R6500/1E I/O Port Initialization

TYPICAL PROGRAM MEMORY INTERCONNECTIONS

Two typical connections between the R6500/1E and program memory (in this case, type 2716 and 2732 PROMS) are illustrated. Figure 4 shows a connection to a 2K 2716 PROM. Since the R6500/1 has a 2K ROM capacity, the contents of the PROM could be masked directly into the production R6500/1 ROM.

Figure 5 shows a connection to a 4K 2732 PROM. Only 3K bytes (\$400-\$FFF) are enabled. The upper 2K bytes correspond the production ROM space (\$800-\$FFF) in the R6500/1. The extra 1K (\$400-\$7FF) allows expanded or additional programs to be used during R6500/1 firmware development. The production program, however, must be reduced to 2K maximum (\$800-\$FFF) before masking into R6500/1 ROM.

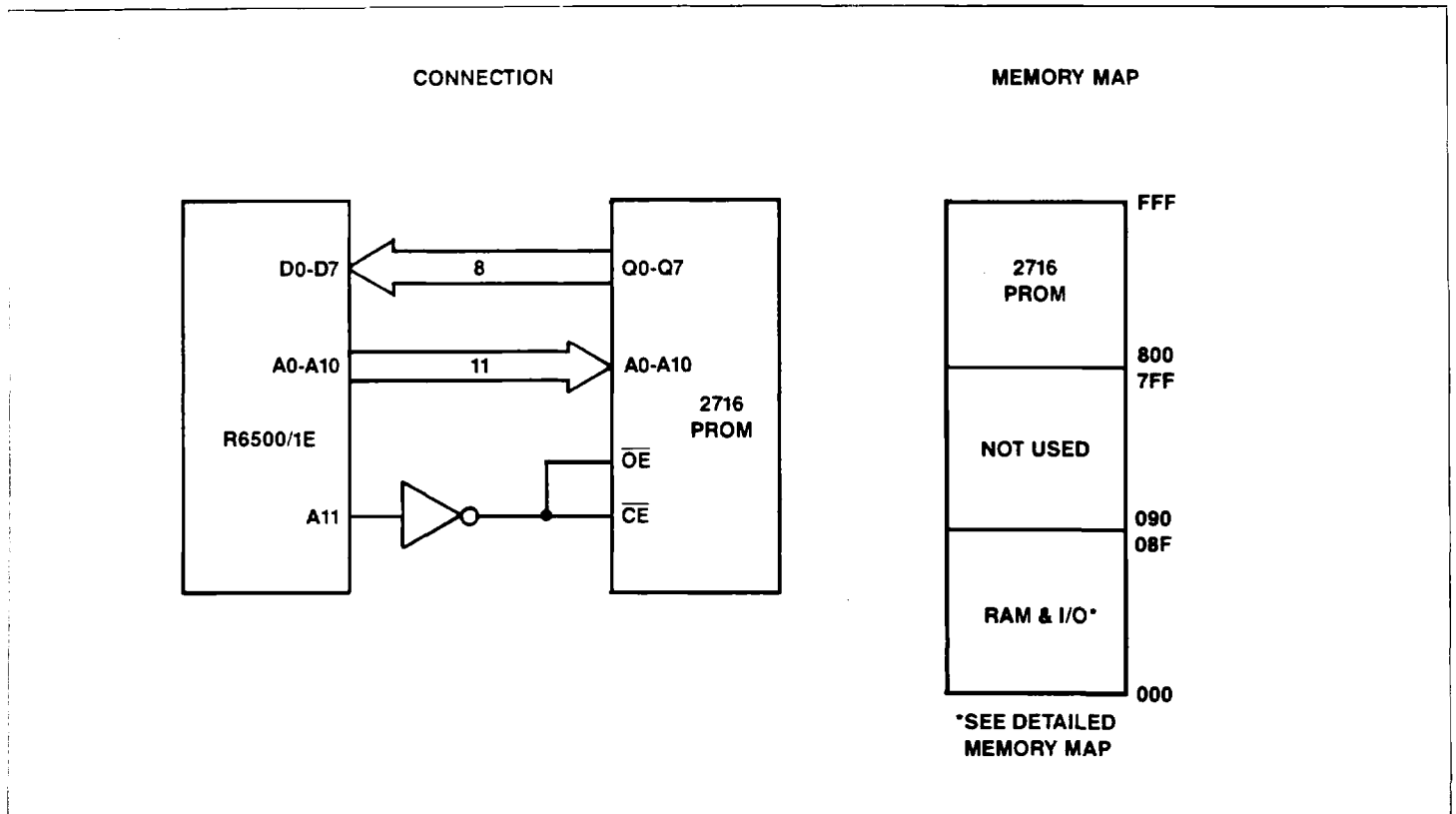

Figure 4. R6500/1E Connected to One 2716 PROM (2K Bytes)

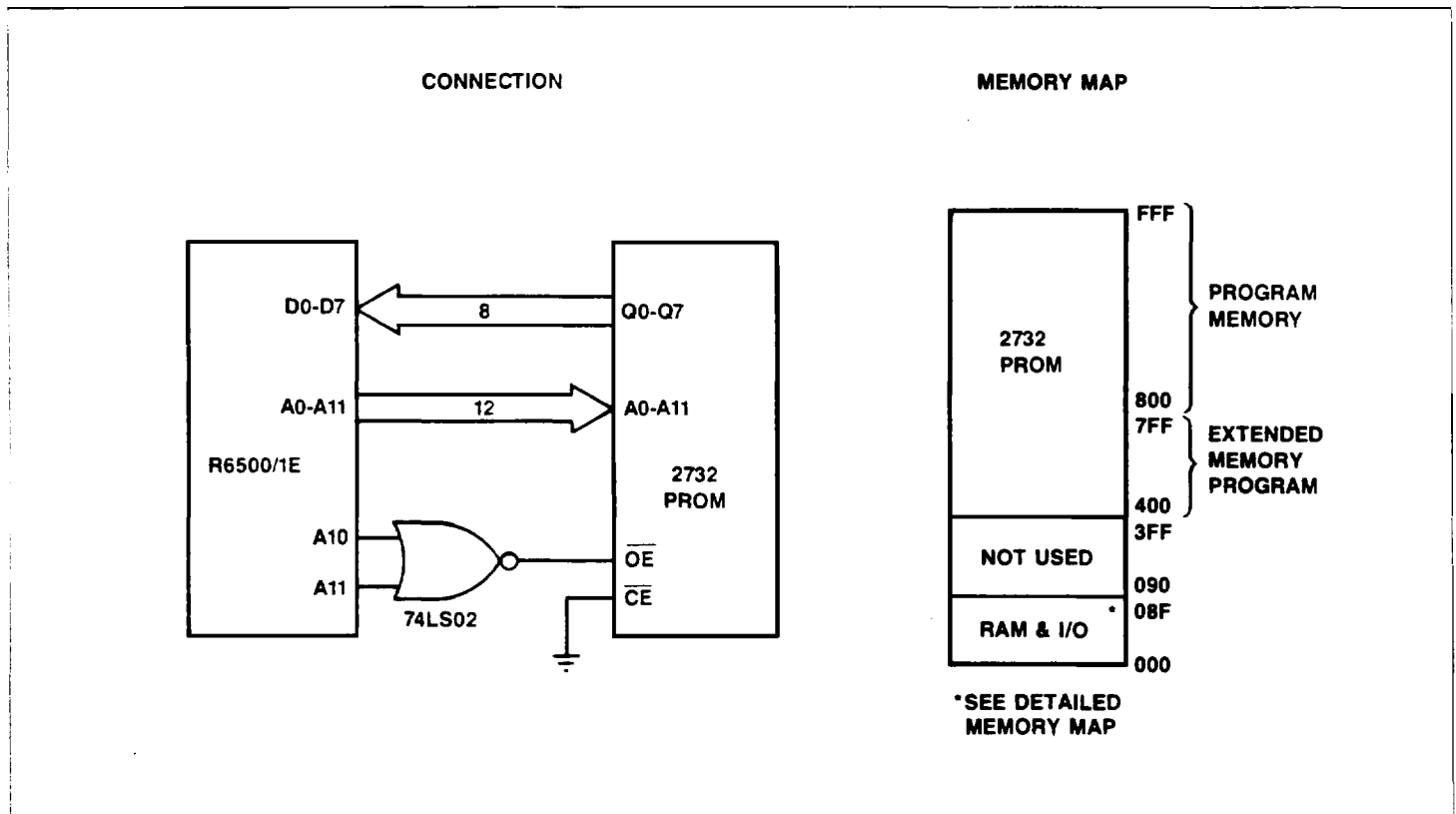
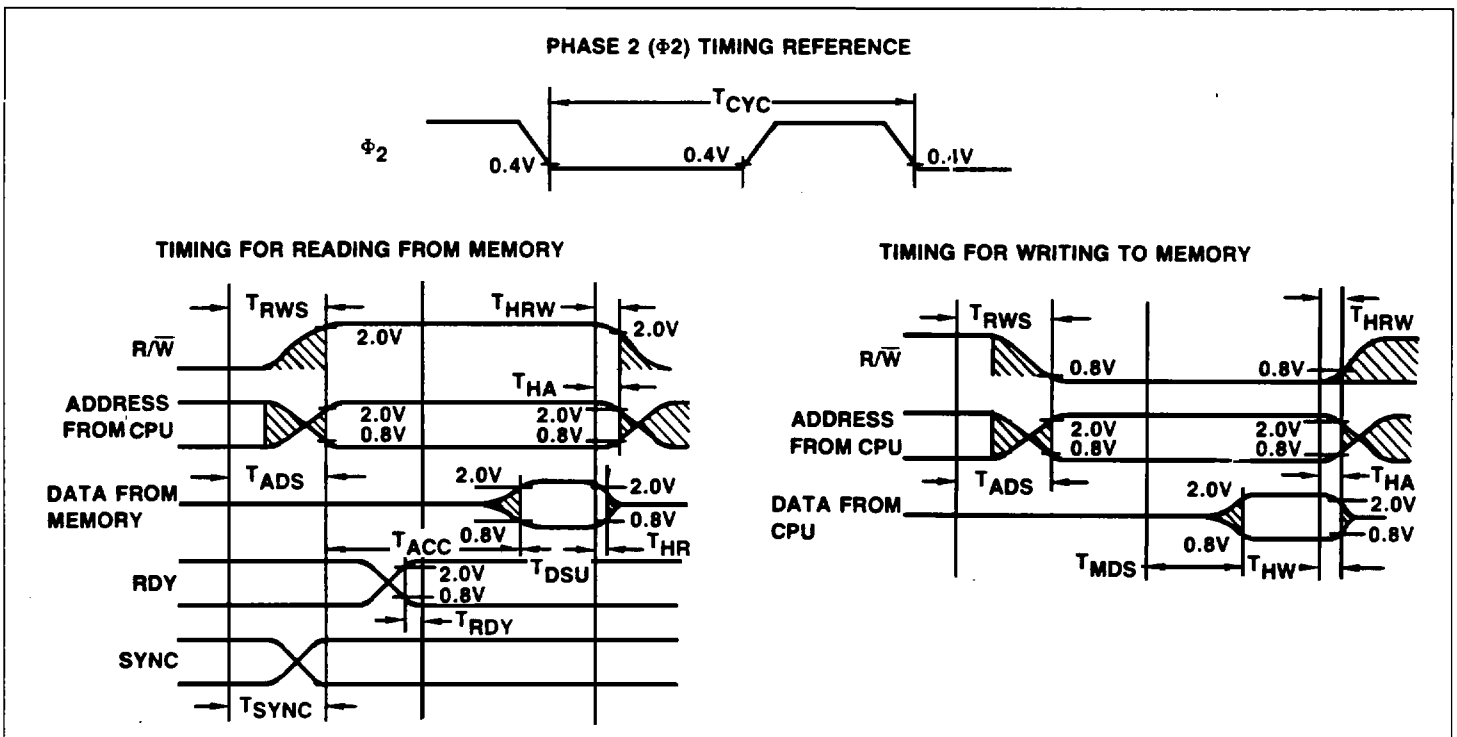

Figure 5. R6500/1E Connected to One 2732 PROM (3K Bytes)

DEVICE TIMING

Signal	Symbol	1 MHz		2 MHz		Unit
		Min.	Max.	Min.	Max.	
R/W setup time from CPU	T _{RWS}		300		200	ns
Address setup time from CPU	T _{ADS}		300		200	ns
Memory read access time	T _{ACC}		525		225	ns
Data stabilization time	T _{DSU}	150		75		ns
Data hold time — Read	T _{HR}	10		10		ns
Data hold time — Write	T _{HW}	30		30		ns
Data delay time from CPU	T _{MDS}		200		150	ns
RDY setup time	T _{RDY}	100		50		ns
SYNC delay time from CPU	T _{SYNC}		350		175	ns
Address hold time	T _{HA}	30		30		ns
R/W hold time	T _{HRW}	30		30		ns
Cycle Time	T _{CYC}	1.0	10.0	0.5	10.0	μs

TIMING DIAGRAMS



MAXIMUM RATINGS*

Parameter	Symbol	Value	Unit
Supply Voltage	V _{CC}	- 0.3 to + 7.0	Vdc
Input Voltage	V _{IN}	- 0.3 to + 7.0	Vdc
Operating Temperature	T _A	0 to + 70	°C
Storage Temperature	T _{STG}	- 55 to + 150	°C

*NOTE: Stresses above those listed may cause permanent damage to the device. This is a stress rating only and functional operation of the device at these or any other conditions above those indicated in other sections of this document is not implied. Exposure to absolute maximum rating conditions for extended periods may affect device reliability.

ELECTRICAL CHARACTERISTICS

(V_{CC} = 5.0 ± 5%, V_{SS} = 0, T_A = 0°C to 70°C unless otherwise specified)

Characteristic	Symbol	Min	Typ	Max	Unit	Test Conditions
RAM Standby Voltage (Retention Mode)	V _{RR}	3.5	—	V _{CC}	V	
RAM Standby Current (Retention Mode)	I _{RR}	—	10	—	mA	
Input High Voltage	V _{IH}	+ 2.4	—	—	Vdc	
Input Low Voltage	V _{IL}	—	—	+ 0.8	Vdc	
Three-State (Off State) Input Current D0-D7	I _{TSI}	—	—	± 10	μA	V _{IN} = 0.4 to 2.4V V _{CC} = 5.25V
Output High Voltage D0-D7, SYNC, A0-A11, R/W, Ø2	V _{OH}	+ 2.4	—	—	Vdc	I _{LOAD} = - 100 μA V _{CC} = 4.75V
Output Low Voltage D0-D7, SYNC, A0-A11, R/W, Ø2	V _{OL}	—	—	+ 0.6	Vdc	I _{LOAD} = 1.6 μA V _{CC} = 4.75V
Power Dissipation (V _{CC} = 5.5V)	P _D	—	750	1200	μW	V _{CC} = 5.5V
Input Capacitance RDY, PA, PB, PC, PD, CNTR D0-D7 XTLI, XTLO	C _{IN}	—	—	10 15 50	pF	T _A = 25°C V _{IN} = 0 f = 1 MHz
Output Capacitance A0-A11, R/W, SYNC Ø2	C _{OUT} C _{Ø2}	—	—	12 80	pF	
I/O Port Pull-up Resistance	R _L	3.0	6.0	11.5	kohm	

Notes:

1. Typical values measured at T_A = 25°C and V_{CC} = 5.0V.
2. Negative sign indicates outward current flow, positive indicates inward flow.

PACKAGE DIMENSIONS

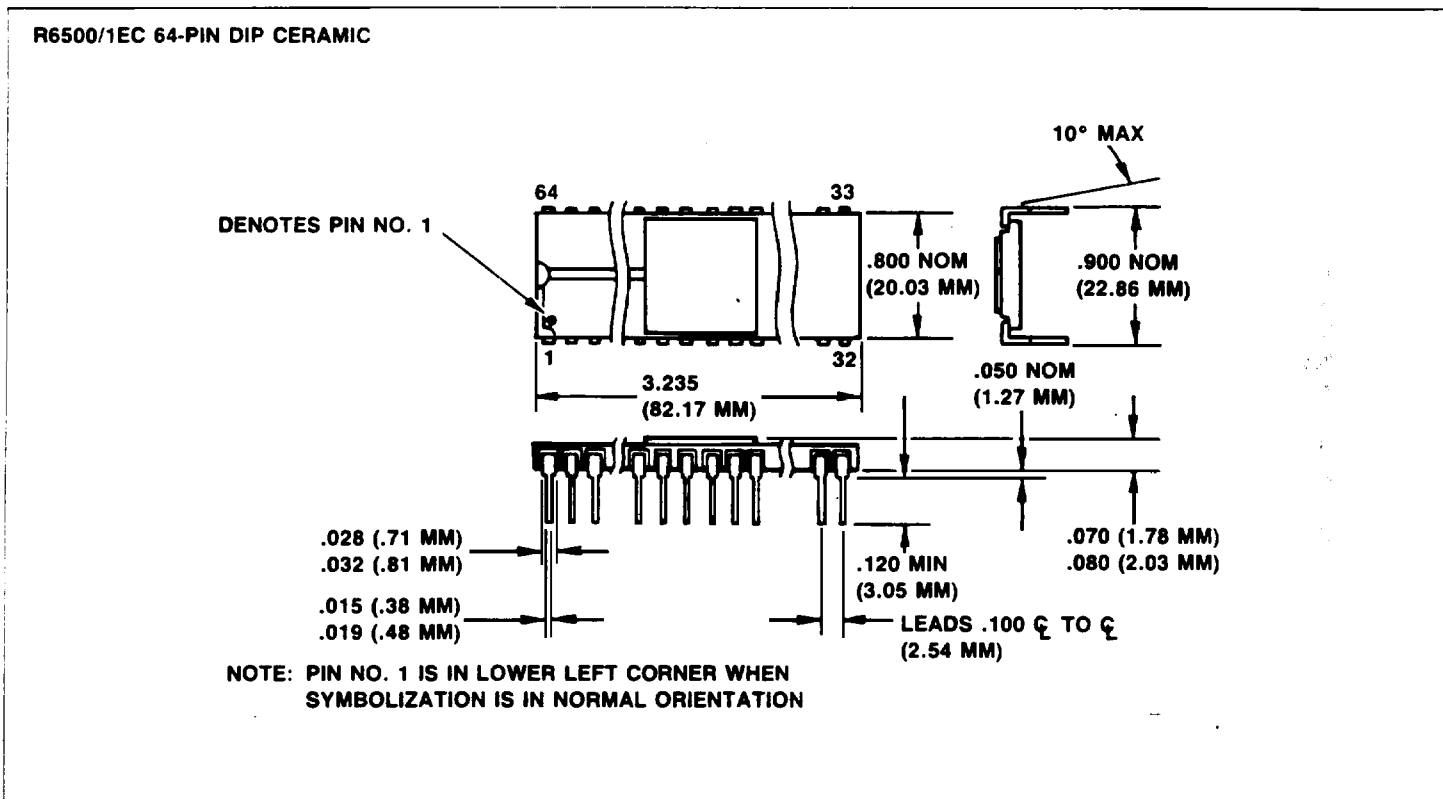

Information furnished by Rockwell International Corporation is believed to be accurate and reliable. However, no responsibility is assumed by Rockwell International for its use, nor any infringement of patents or other rights of third parties which may result from its use. No license is granted by implication or otherwise under any patent rights of Rockwell International other than for circuitry embodied in Rockwell products. Rockwell International reserves the right to change circuitry at any time without notice. This document subject to change without notice.

DIGITAL COMMUNICATIONS DIVISION REGIONAL SALES OFFICES

Headquarters

Digital Communications Division
Rockwell International
4311 Jamboree Road
P.O. Box C
Newport Beach, CA 92658-8902
Tel: (714) 833-4600
Fax: (714) 833-4078
Fax: (714) 833-4391

USA - Southwest

Digital Communications Division
Rockwell International
5000 Birch Street
Suite 400
Newport Beach, CA 92660
Tel: (714) 833-4655
Fax: (714) 833-6898

USA - Southeast

Digital Communications Division
Rockwell International
One Copley Parkway
Suite 210
Morrisville, NC 27560
Tel: (919) 467-7703
Fax: (919) 467-6096

USA - South Central

Digital Communications Division
Rockwell International
2001 N. Collins Blvd.
Suite 103
Richardson, TX 75080
Tel: (214) 994-4020
Fax: (214) 994-4028

USA - North Central

Digital Communications Division
Rockwell International
3158 South River Road
Suite 204
Des Plaines, IL 60018
Tel: (708) 297-8875
Fax: (708) 297-3230

USA - Mid Atlantic

Digital Communications Division
Rockwell International
5001-B Greentree
Executive Campus
Route 73
Marlton, NJ 08053
Tel: (609) 596-0090
Fax: (609) 596-5681

USA - Northeast (and Canada East)

Digital Communications Division
Rockwell International
239 Littleton Road
Suite 1B
Westford, MA 01886
Tel: (508) 692-7660
Fax: (508) 692-8185

USA - Northwest (and Canada West)

Digital Communications Division
Rockwell International
3600 Pruneridge Avenue
Suite 10C
Santa Clara, CA 95051
Tel: (408) 249-9696
Fax: (408) 249-6518

Australia

Digital Communications Division
Rockwell International
3 Thomas Holt Drive
P.O. Box 165
North Ryde, NSW 2113
Australia
Tel: (61-2) 805-5555
Fax: (61-2) 805-5599

France

Digital Communications Division
Rockwell International
Tour GAN, 16 Place de l'Inis
Cedex 13
92082 Paris La Defense 2
France
Tel: (33-1) 49-06-39-80
Fax: (33-1) 49-06-39-90

Germany

Digital Communications Division
Rockwell International GmbH
Paul-Gerhardt-Allee 50 a
8000 München 60
Germany
Tel: (49-89) 829-1320
Fax: (49-89) 834-2734

Hong Kong

Digital Communications Division
Rockwell International
13th Floor
Suites 6-10, Harbour Centre
25 Harbour Road
Wanchai, Hong Kong
Tel: (852) 827-0181
Fax: (852) 827-6488

Italy

Digital Communications Division
Rockwell International Corporation
Via Tonona, 33
20144 Milano
Italy
Tel: (39-2) 47790-226
Fax: (39-2) 4120-642

Japan

Digital Communications Division
Rockwell International Japan Co., Ltd.
Sogo Hanzomon Building, 8F
1-7 Kojimachi, Chiyoda-ku
Tokyo, 102
Japan
Tel: (81-3) 3265-8808
Fax: (81-3) 3263-0639

Korea

Digital Communications Division
Rockwell International
Rm. 608 Leema Building
146-1 Soosong-Dong
Chongro-Ku
Seoul
Korea
Tel: (82-2) 736-9121
Fax: (82-2) 736-9124

Taiwan

Digital Communications Division
Rockwell International
Room 2808
International Trade Building
333 Keelung Road, Section 1
Taipei, Taiwan 10548
R.O.C.
Tel: (886-2) 720-0282
Fax: (886-2) 757-6760

United Kingdom

Digital Communications Division
Rockwell International Ltd.
Central House
3, Lampton Road
Hounslow, Middlesex TW3 1HY
England
Tel: (44-81) 577-1034
Fax: (44-81) 570-0758